

# PHILCO . . . . . Model 37-60



**Special Date for Members of  
RADIO MANUFACTURERS SERVICE**  
A PHILCO SERVICE PLAN

**SERVICE BULLETIN  
No. 245**

## Model 37-60 General Description

Model 37-60 is a 5 tube superheterodyne receiver for operation on alternating current and has two tuning ranges, covering Standard Broadcast and American short-wave reception up to 7 megacycles. The new Philco High Efficiency self-centering glass tubes are used.

The circuit incorporates the Philco Aerial Tuning System—controlled by the range switch—which provides maximum sensitivity and noise reduction when used with the Philco All Wave Aerial.

The red and black leads of the All Wave Aerial "transmission line" are connected to terminals 1 and 2 respectively, of the terminal panel provided at the rear of the chassis. Connect the jumper of the terminal panel across terminals 3 and 4.

If a temporary aerial is used, the jumper should be across terminal 2 and 3. The aerial connects to terminal 1 and the ground to terminals 3. A good ground connection is required in all installations.

### CONSTRUCTION

The chassis is constructed in three basic assembly units.

The Radio Frequency unit contains a 6A8G tube which functions as a Detector-Oscillator, tuning condenser, antenna and oscillator coils for each tuning range, selector switch—compensating condensers for all coils and other parts necessary for the associated circuits. The unit is separately mounted on rubber grommets, cushioning it from the main chassis.

The Intermediate Frequency unit, mounted on the right-hand side of the chassis (facing the front) consists of the Intermediate

Frequency coils compensating condensers, a 6K7G tube for I. F. Amplifier stage, and a 6Q7G tube as the second detector-automatic volume control and first audio stage.

All voltages supplied to the I. F. and R. F. units are furnished from a terminal strip mounted in this unit.

The Power Pack and audio output circuits, together with the required Voltage dividers and filter condensers are mounted in the power unit. All high Voltage A. C. Wiring is housed in the power transformer assembly which includes the rectifier socket.

Although unit construction has changed the appearance of this model, the service bulletin will be of great assistance in checking through all stages of the receiver. The Wiring Diagram, as usual, is numbered, indicating all important parts. These numbers correspond with the parts layout shown in Fig. 6. In addition, the range switch wafers are shown on the schematic diagram. The contacts on each wafer are lettered and numbered to indicate their connection points in the schematic diagram, which are also lettered and numbered. The physical drawings of each coil used in the receiver are also shown on schematic diagram Fig. 5. The connections of these coils are numbered on the coil itself and on the schematic diagram.

Fig. 1 shows the Voltage measurements taken from the bottom of the socket at each contact. In Fig. 2, the correct position of the dial indicator, for proper adjustment of the compensators is shown. Figs. 3 and 4, are the location of the I. F. and R. F. compensators respectively.

This Receiver is supplied in two models, type B and type F. These instructions, however, are used for both types.

## Electrical Specifications

**Voltage Rating:** 115 Volts. A. C.

**Frequency Rating:** 50-60 Cycle.

For 25-40 cycle operation use Power Transformer, marked with asterisks in Parts List.

**Power Consumption:** 60 Watts.

**Type and Number of Philco Tubes:** 1 type 6A8G First Detector-oscillator; 1 type 6K7G I. F. Amplifier; 1 type 6Q7G

2nd Detector, A. V. C., and 1st Audio; 1 type 6F6G Pentode Output and 1 type 5Y4G, Rectifier.

**Speaker:** S7.

**Type of Circuit:** Superheterodyne with Pentode Power Output.

**Intermediate Frequency:** 470 K. C.

**Undistorted Power Output:** 3 Watts.

**Tuning Ranges:** Two—(1): 530 to 1720 K.C., (2): 2.3 to 7.4 M.C.

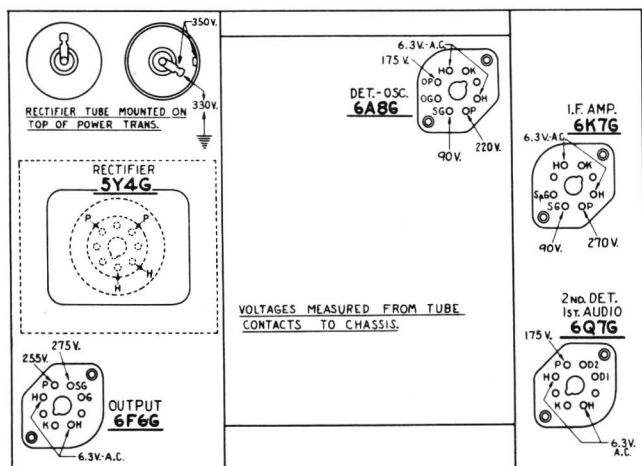

**Fig. 1—Socket Voltages  
Viewed from Underside of Chassis**

Measurements taken with Philco Model 025 Circuit Tester which contains a 1000 ohm per volt voltmeter. Line voltage, 115—Wave Switch in Broadcast Position. Dial turned to 600 K.C.

### POWER TRANSFORMER DATA

Lead No. Shown on Schematic	A. C. Volts	Current	Circuit	Color	Resistance
1-2	120	—	Primary	White	50 ohms
5-7	670	70 M. A.	High Voltage Sec.	Yellow	145 ohms 155 ohms
3-4	5.0	2.0 A	Fil. Rect.	Blue	.1 ohms
8-9	6.7	2.1 A	Fil.	Black	.1 ohms
6	—	—	Center Tap of 5-7	Yellow Green Tr	—

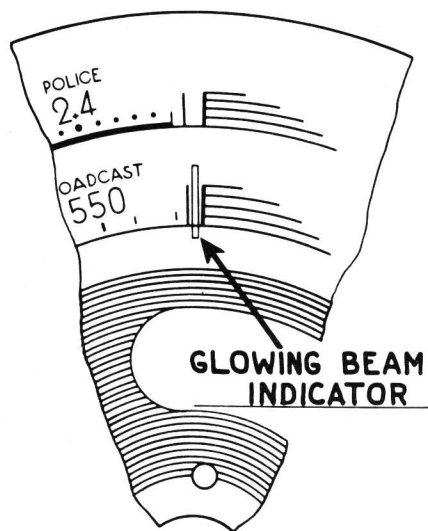
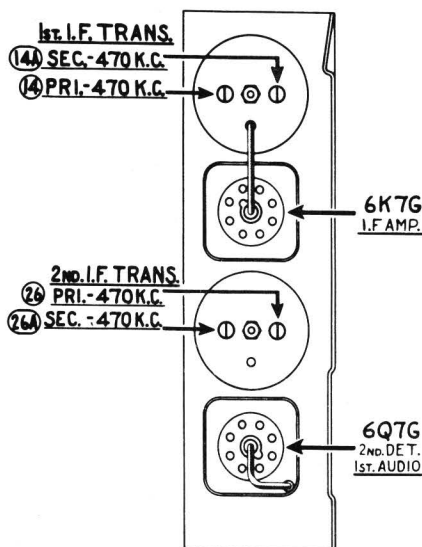
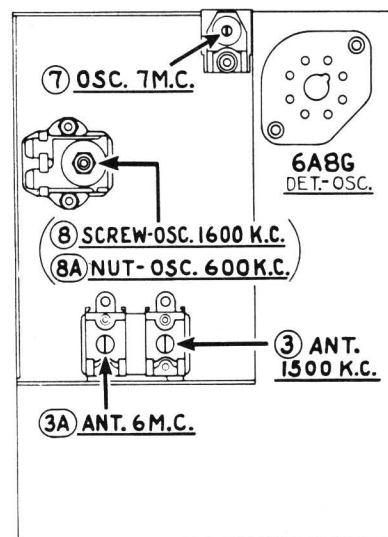

Fig. 2—Dial Calibration

Fig. 3—Locations of  
I. F. Compensators Top of ChassisFig. 4—Locations of  
R. F. Compensators Underside of  
Chassis

## Adjustment of Compensators

The accurate adjustment of the various compensating condensers is vital to the proper functioning of this receiver. There are four compensating condensers in the I. F. Circuit, three in the Oscillator Circuit, and two in the Antenna Circuit. Incorrect adjustment will cause loss of sensitivity, unsatisfactory tone, and poor selectivity.

To accurately adjust this receiver, precision test equipment is necessary. A signal generator such as the PHILCO MODEL 088 SIGNAL GENERATOR, covering from 110 to 20,000 K. C. is recommended to adjust the compensators at the various frequencies specified. A visual indication of the receiver output is also necessary to obtain correct adjustment of the compensators. PHILCO MODEL 025 CIRCUIT TESTER contains a very sensitive output meter and is recommended for these adjustments.

Philco Fibre Wrench No. 3164 and Fibre Handle Screw-driver No. 27-7059 complete the necessary equipment for these adjustments. The locations of the various compensators are shown in Figs. 3 and 4.

The following procedure must be observed in adjusting the compensators:

**DIAL ADJUSTMENT**—The Tuning condenser is set at the maximum capacity position, by turning the tuning knob counter-clockwise. Loosen the set screw of dial hub and set dial, (see Fig. 2) with Glowing Indicator centered between the index lines at the low frequency end of scale.

**OUTPUT METER**—The Output Meter is attached to the Plate and Cathode terminals of the (6F6G tube) and adjusted to use the (0-30) volt scale. When adjusting each circuit, care should be taken to have the signal generator attenuator set to give approximately  $\frac{1}{4}$  scale reading on output meter.

### INTERMEDIATE FREQUENCY CIRCUIT

- Turn wave band switch to Range 1. Rotate the tuning control to approximately 600 K. C. Connect the 088 Signal Generator output lead through a .1 mfd. condenser to the grid of the 6A8G tube, and the ground lead of Signal Generator to the chassis.
- Set Signal Generator indicator for 470 K. C., adjust attenuator for approximately  $\frac{1}{4}$  scale reading on output meter. Then adjust compensators (26a) 2nd I. F. Sec., (26) 2nd I. F. Pri., (14a) 1st I. F. Sec., (14) 1st I. F. Pri., for maximum reading on output meter.

### RADIO FREQUENCY CIRCUIT—Range 2: 2.3 to 7.4 M. C.

- Turn Range switch to Range 2. Remove signal generator output lead from the grid of 6A8G tube.
- Attach signal generator output lead through a 0.1 mfd. condenser to the ANT. TERMINAL No. 1, on aerial panel, and the generator ground to chassis. Connect TERMINAL No. 2, to GROUND TERMINAL No. 3, with connector link provided on the panel.
- Set Signal Generator and receiver dials for 7.0 M. C. Now adjust compensator (7) for maximum reading on output meter. Then turn Signal Generator and Receiver to 6.0 M. C., and adjust compensator (3a) for maximum output.

### RANGE 1: 530 to 1720 K. C.

- Turn range switch to Range 1. Turn the Receiver dial to 1600 K. C. Then adjust compensators (8) and (3) for maximum reading on output meter.

The 088 Signal Generator dial is set at 800 K. C. and the second harmonic of this frequency (1600 K. C.) is used in making the above adjustment.

- The low frequency end of the band is now tuned by turning Signal Generator and Receiver dials to 600 K. C. and adjusting compensator (8a)—see note (a) below—for maximum output.

(a) When compensator (8a) osc. series is being adjusted, the Tuning Condenser must be rolled for maximum output. This is accomplished as follows: First tune compensator (8a) for maximum output. Then vary the Tuning Condenser for maximum output at 600 K. C. Now retune Compensator (8a), and again vary the tuning condenser back and forth about 600 K. C., for maximum output. This operation of first tuning the Compensator, then the Tuning Condenser is continued until maximum output is obtained at the 600 K. C. frequency.

- Set the Signal Generator and Receiver dials for 1600 K. C. and re-adjust Compensator (8) for maximum output. Then turn the dials to 1500 K. C. and re-adjust compensator (3) for maximum reading on output meter.

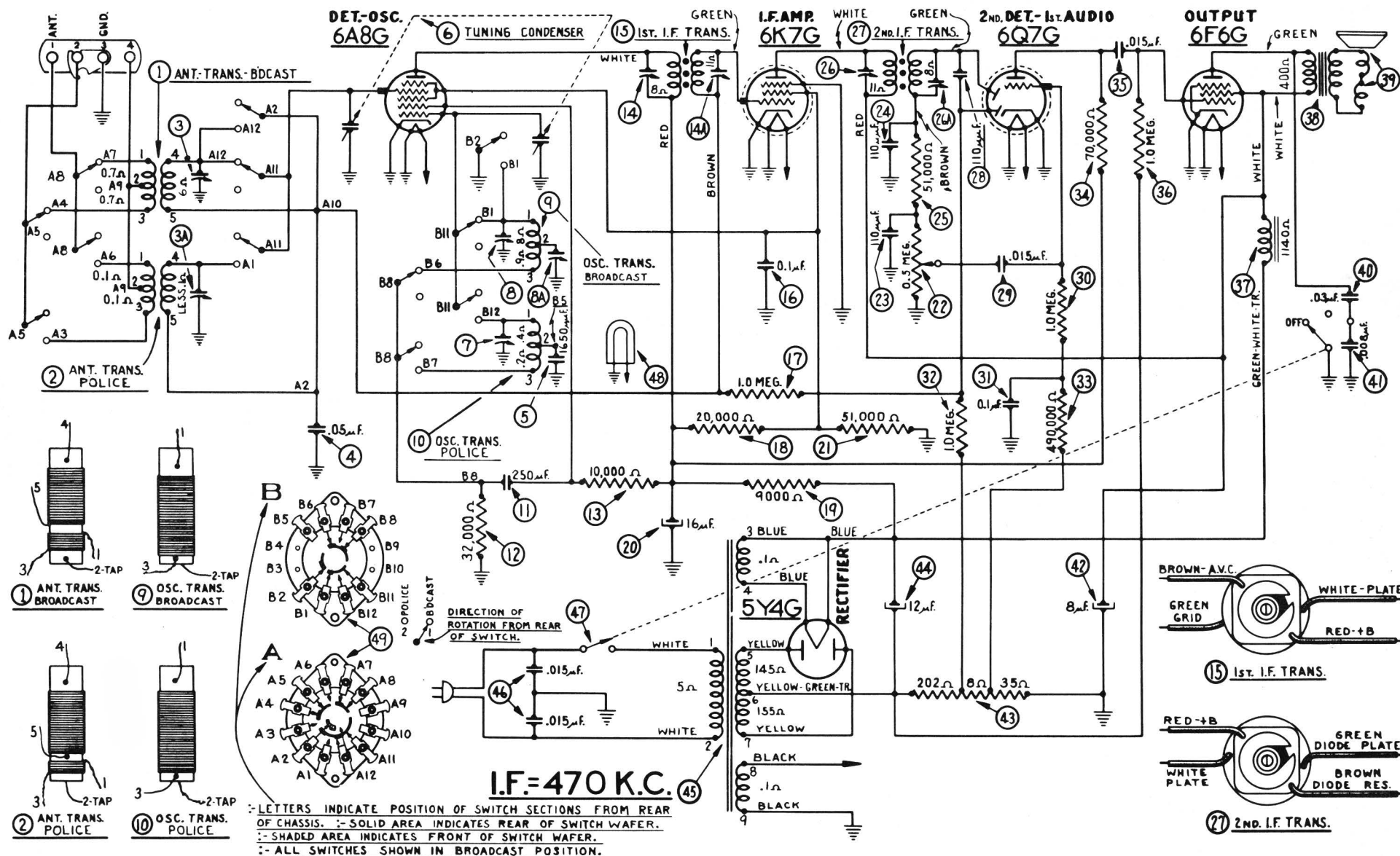

Fig. 5—Schematic Diagram—Model 37-60

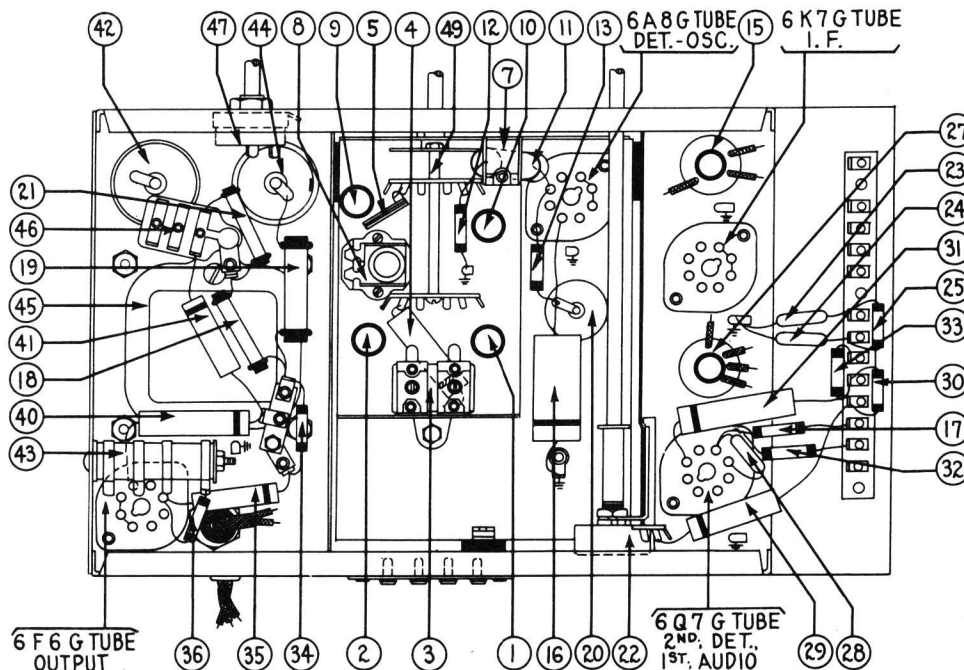

Fig. 6—Base View of Chassis

**Replacement Parts—Model 37-60**

Schem. No.	Description	Part No.	Price List	Schem. No.	Description	Part No.	Price List
①	Antenna Transformer (Broadcast)	32-2108	\$0.80	④⑦	Tone Control & Power Switch	42-1180	\$0.75
②	Antenna Transformer (Police)	32-2119	.65	④⑧	Pilot Lamp	34-2039	.15
③	Compensator ANT 1600 K.C.	31-6093	.40	④⑨	Wave Switch	42-1195	1.50
③A	ANT. Compensator 6 meg.	Part of ③			Dial	27-5196	.30
④	Condenser (.05 mfd. Tubular)	30-4444	.20		Dial Hub	28-7152 FA-3	.10
⑤	Condenser (1650 mfd. Semi-fixed)	31-6096	.40		Dial Hub Clamp	28-2837 FA-3	.10
⑥	Tuning Condenser	31-1826	3.00		Set Screw	N-1506	Per C 2.00
⑦	Oscillator Compensator (Police 7 M.C.)	31-6101	.20		Screen Bracket & Screen Assembly	31-1878	.25
⑧	Oscillator Compensator (Broadcast) 1600 K.C. Screw	31-6100	.40		Pilot Lamp Socket Assembly	38-7706	.35
⑧A	Compensator (600 K.C. Nut)	Part of ⑧			Tube Socket 7 Prong	27-6057	.11
⑨	Oscillator Transformer (Broadcast)	32-2120	.65		Tube Socket 8 Prong	27-6058	.11
⑩	Oscillator Transformer (Police)	32-2121	.40		Tube Shield	28-2726	.10
⑪	Condenser (.250 mmfd. Mica)	30-1032	.25		Tube Shield Base	28-3898	.03
⑫	Resistor (32000 ohms 1/2 watt)	33-332339	.20		I. F. Coil Shield	38-7763	.20
⑬	Resistor (10000 1/2 watt)	33-310339	.20		R.F. Trans. Mtg. Plate	28-3808	.02
⑭	Compensator (Pri. 1st I.F.)	Part of ⑬			R.F. Trans. Mtg. Spacer	27-8228	.01
⑭A	Compensator (Sec. 1st I.F.)	Part of ⑬			R.F. Trans. Mtg. Screw	W-1635	Per C .30
⑮	1st I.F. Transformer	32-2100	1.50		R.F. Mtg. Grommet	27-4317	.04
⑯	Condenser (.1 mfd. Tubular)	30-4170	.25		R.F. Mtg. Sleeve	28-2257 FA-3	.01
⑰	Resistor (1 meg. 1/2 watt)	33-510344	.20		R.F. Mtg. Bushing	27-8339	Per C .40
⑱	Resistor (20000 ohms 1 watt)	33-320439	.20		Screw	W-729	
⑲	Resistor (9000 ohms 2 watts)	33-290539	.30		Vernier Drive Assem.	31-1879	
⑳	Electrolytic Condenser (16 mfd.)	30-2118	1.65		B.C. Resistor Mtg. Screw	W-512	Per C .90
㉑	Resistor (51000 ohms 1 watt)	33-351439	.20		B.C. Resistor Mtg. Nut	W-317A	Per C .40
㉒	Volume Control	33-5157	1.00		Volume Control Shaft	28-6498	
㉓	Condenser (mica 110 mmfd.)	30-1031	.20		Volume Control Shaft Spring	28-4117	Per C .40
㉔	Condenser (mica 110 mmfd.)	30-1031	.20		Washer Volume Control Shaft	28-4186	
㉕	Resistor (51000 ohms 1/2 watt)	33-351339	.20		Washer Volume Control Shaft	4436	Per C 1.50
㉖	Compensator 2nd I.F. Pri.	Part of ㉕			Volume Control Shaft Retaining Clip	28-8610	.03
㉖A	Compensator 2nd I.F. Sec.	Part of ㉕			Volume Control Mtg. Nut	W-684 FA-3	Per C 1.25
㉗	2nd I.F. Transformer Unit	32-2102	1.50		Tone Control Mtg. Nut	W-684 FA-3	Per C 1.25
㉘	Condenser (mica 110 mmfd.)	30-1031	.20		Insulator	27-8320	Per C .40
㉙	Condenser (Tubular .015 mfd.)	30-4358	.20		I.F. Terminal Panel	38-7703	.25
㉚	Resistor (1 meg. 1/2 watt)	33-510339	.20		I.F. Terminal Spacer	4122	.01
㉛	Condenser (Tubular .1 mfd.)	30-4122	.20		Knob Tuning	27-4321	.10
㉜	Resistor (1 megohm 1/2 watt)	33-510339	.20		Knob Volume, Tone	27-4332	.10
㉝	Resistor (490000 ohm 1/2 watt)	33-449339	.20		Knob Selector Switch	27-4332	.10
㉞	Resistor (70000 ohm 1/2 watt)	33-370339	.20		Chassis Mtg. Screw		
㉟	Condenser (Tubular .015 mfd.)	30-4226	.20		Tuning Condenser Grommet	27-4325	.02
㊱	Resistor (1 meg. 1/2 watt)	33-510339	.20		Screw	W-650 FA-3	Per C .40
㊲	Field Coil Assembly	36-3039	2.75		Baffle Assembly B Cabinet	40-5935	
㊳	Output Transformer	32-7019			A.C. Cord	L-2183	.40
㊴	Cone & Voice Coil Assembly	36-3157	.80		Speaker Cable	L-2181	.25
㊵	Condenser (Tubular .03 mfd.)	30-4380	.20		Clamp Electrolytic Condenser	6440	.05
㊶	Condenser (Tubular .008 mfd.)	30-4112	.20		Insulator Electrolytic Condenser	27-7194	.01
㊷	Electrolytic Condenser (8 mfd.)	30-2024	1.10		Grid Cap	38-3888	.01
㊸	Bias Resistor	33-3277	.20		Spacer (Compensating Condenser)	29-6032	.04
㊹	Electrolytic Condenser (12 mfd.)	30-2117	1.20		Screw	W-1653 FA-3	Per C .30
㊺	Power Transformer (50-60 cycle, 115 volts)	32-7583	4.25		†B Speaker S-7	36-1009	5.75
*	Power Transformer (25-40 cycle, 115 volts)	32-7584			Nut Mtg. Speaker	W-124 A	Per C 1.35
㊻	Condenser (Bakelite Twin .015 mfd.)	3793 DG	.40		Baffle Assem. F Cabinet	40-5933	

\*25 cycle Transformer 32-7584 used in Model 37-60A.  
†Speaker used in F & B Cabinet.